

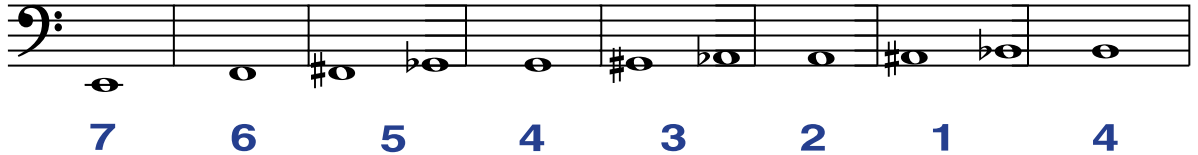

The figures appearing below the notes represent slide positions.

E F F# Gb G G# Ab A A# Bb B



C C# Db D D# Eb E F F# Gb



G G# Ab A A# Bb B C C# Db D



D# Eb E F F# Gb G G# Ab A A# Bb

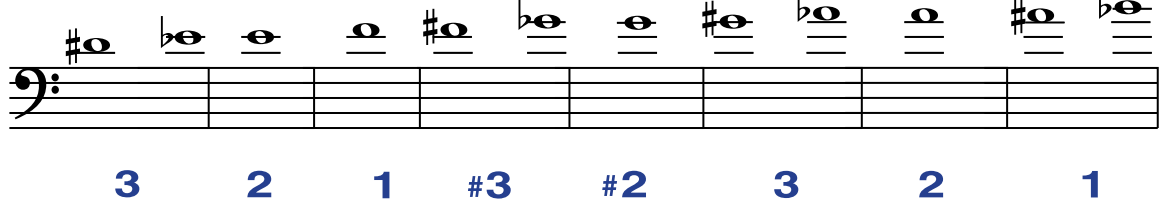
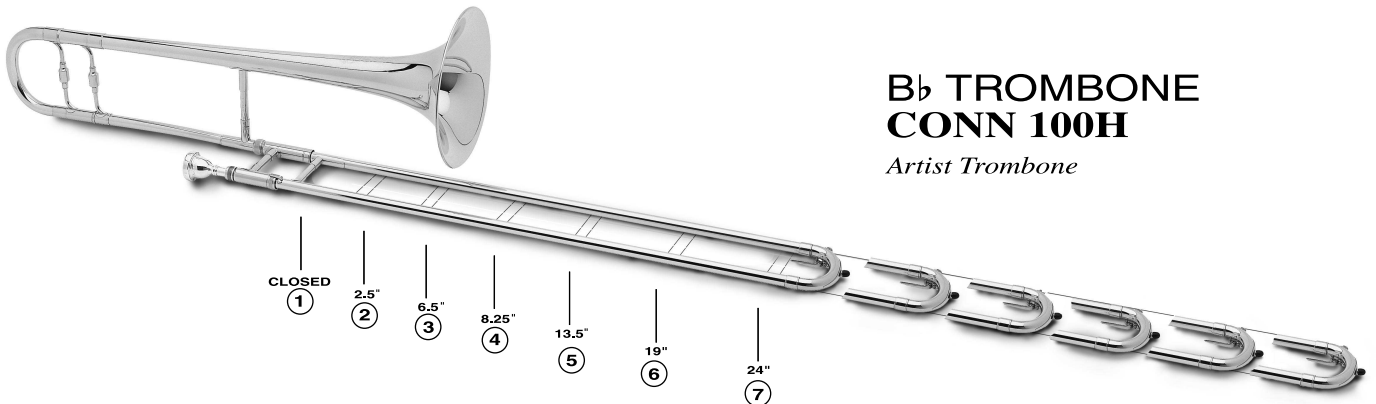



**B \flat TROMBONE
CONN 100H**

Artist Trombone

The figures appearing in the bottom row below the notes in the first and second lines represent the positions used for playing Bb Trombone with F valve attachment. "T" prefix indicates that F change valve or "trigger" is to be depressed, thereby changing the instrument to the key of F. Approximate F trombone slide locations below are in relation to the Bb Trombone positions - 2 1/4 is slightly below the normal 2nd position, 3 1/2 is halfway between the 3rd and 4th, etc.

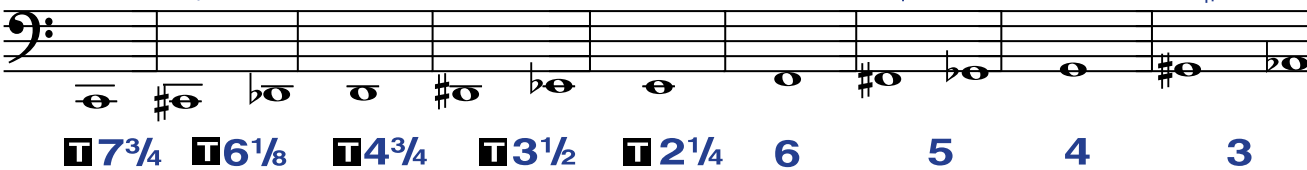
C C# D \flat D D# E \flat E F F# G \flat G G# A \flat



T7 $\frac{3}{4}$ T6 $\frac{1}{8}$ T4 $\frac{3}{4}$ T3 $\frac{1}{2}$ T2 $\frac{1}{4}$ 6 5 4 3

A A# B \flat B C C# D \flat D D# E \flat E F



T4 $\frac{3}{4}$ T3 $\frac{1}{2}$ T2 $\frac{1}{4}$ T1 5 4 3 2 1

F# G \flat G G# A \flat A A# B \flat B C C# D \flat D



5 4 3 2 1 4 3 2 1

D# E \flat E F F# G \flat G G# A \flat A A# B \flat

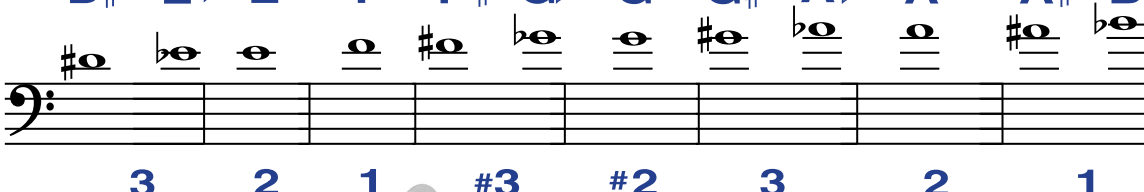

3 2 1 #3 #2 3 2 1

